

Wheatstone Corporation Technical Documentation

Making The Connection

Handling Telephone Call-Ins With Your
Audioarts Engineering Radio Console



600 Industrial Drive
New Bern, NC 28562
252.638.7000
www.wheatstone.com

Rev 1.1 – June, 2010
Dick Webb

Table of Contents

1. Introduction To Handling Caller Segments.....	3
1.1 General Issues.....	3
1.2 Interface Problems.....	3
1.2.1 Electrical Conditions.....	4
1.2.2 Required Features.....	4
1.3 Solutions.....	4
1.4 Do I Really Need A Hybrid?.....	4
1.5 A Quick Quiz.....	5
1.6 What Can I Expect From The Console?.....	5
1.6.1 Consoles Without Dedicated Caller Hardware.....	5
1.6.2 Consoles With Dedicated Caller Hardware.....	6
2. Handling A Single Caller.....	6
2.1 Getting Caller Audio To The Console.....	6
2.2 Getting Audio Back To The Caller.....	7
2.2.1 Mix Minus.....	7
2.2.2 Generating The Mix Minus.....	8
2.2.3 What's In The Mix.....	9
2.3 Off Air.....	9
2.4 On Air.....	10
2.5 Recording.....	10
2.5.1 Other Phone Specific Outputs.....	10
3. Handling Two Callers.....	10
3.1 Conferencing.....	11
3.1.1 Too Much Conferencing.....	11
3.1.2 Not Enough Conferencing.....	12
3.2 Two Callers, One Caller Channel.....	13
3.2.1 A Simple Example.....	13
3.2.2 Other Consoles, Other Methods.....	14
4. Handling More Than Two Callers.....	14
5. Logic.....	15
6. Summary.....	15
NOTES.....	16
APPENDIX.....	16

1. Introduction To Handling Caller Segments

When I talk to customers, one of the topics that comes up with regularity is the handling of telephone calls. How do I connect to the phone system? Do I need a hybrid? Just what is a hybrid anyway? Why is the caller not hearing me? Why can't I hear the caller? What's up with the delay and/or feedback I'm hearing?

The fact is that dealing with telephone callers in the radio broadcast environment is a little different than doing some announcing or playing some music. The object of this paper is to help you, whether you are the installer, operator, or program manager, to gain a little insight and understanding into the somewhat mysterious world of telephone conversation broadcasting.

To this end, we will begin with a discussion of the issues involved in interfacing the telephone world to the broadcast world. Then we will look at some of the equipment involved, and what we expect that equipment to do to help us achieve our goal of being able to broadcast telephone talk. This leads naturally into a discussion of how the equipment is connected, and, of course, how it is operated.

1.1 General Issues

Why is there a problem with handling telephone calls in a radio broadcast situation? What are the issues involved? Why is this so hard?

So what *are* the issues? First, there is the fact that balanced, professional level audio, or even unbalanced, commercial level audio, is *not the same as telephone audio*. For that matter, not all telephone audio is created equal.

Once upon a time, if you had a telephone, it was connected to a POTS, or Plain Old Telephone Service. Although the days are long gone when we can be so certain, there are certainly still a lot of us connected to a POTS. And that may be what we have in our studio, that listeners will be calling us on.

I suppose that if this was the only kind of system we had to worry about, life would be easier.

What else might we encounter these days? Well, there's ISDN, which stands for Integrated Service Digital Network. Since POTS is analog, the key word here is “digital.”

And then there's DSL, or Digital Subscriber Line. Once again, digital. Interestingly, the term DSL may be applied to ISDN, but also applies to other types of systems. And you may see the term xDSL, which refers to the fact that there is more than one type of DSL.

The purpose of this paper is not to go into great depth about the characteristics of these different types of phone lines, so it is enough to let you know that there are different systems out there.

1.2 Interface Problems

There are a myriad of problems encountered in trying to fit the telephone call into our broadcast routine, and we're going to list a few of them here. Once again, the plan is not to go into great detail, but just outline some of the challenges that are faced. Once we've got this under our belt we can proceed to some solutions.

1.2.1 Electrical Conditions

The POTS is an analog system, but the voltages and impedances are not compatible with state of the art professional audio equipment. Voltages of a magnitude that can cause damage to the op-amps used in today's pro audio equipment are present in the POTS. The system is powered from -48V, and the ring voltage, which may be as high as 130 VRMS, rides on this dc offset.

Audio levels are not consistent with pro or consumer grade audio standards. And the phone system is usually limited in bandwidth, unless digital techniques are applied.

Line noise may be excessive, especially outside of the limited usable phone system bandwidth.

The phone jack we have access to is usually a 2 wire system, mixing the audio in both directions onto a common path. Part of what the telephone receiver does is to separate the send and receive audio so that we can deal with each separately.

Digital phone systems can address some of these concerns, but they come with their own set of challenges. The various digital formats are not the same as AES-3 audio and thus cannot be directly connected to the console's phone connections, even if the console can handle digital audio.

1.2.2 Required Features

We may need to have more than one caller on the line at the same time. And while all callers may be live to air at the same time they usually aren't. Further, we may want the callers to hear each other, a feature known as "conferencing," or then again we may not.

We may want the caller to hear one thing while we have them live on air, and something completely different when they're on hold. Or not.

We may want to record the callers, or some of them, or none of them.

And we certainly do not want the callers' voices getting back to them, which requires a feature known as "mix-minus" that we'll discuss in a bit.

1.3 Solutions

We need to figure out how we can overcome these obstacles. One way to deal with all of these issues is to divide the problem between two pieces of equipment. This is the Audioarts Engineering approach. We at Audioarts Engineering do what we do best, which is provide the finest in professional grade audio equipment that is equally at home in the broadcast world and the recording studio, and leave the messy details of the physical interface to the phone system to a piece of equipment known as a hybrid, as we will see next.

1.4 Do I Really Need A Hybrid?

The telephone hybrid is a device that, on one end, connects to the phone system, and, on the other end, connects to the Audioarts Engineering console. One of the most common calls we get relating to operation with a telephone system is "Do I have to use a hybrid?"

There are basically three answers to this question:

1. Yes

2. Most certainly, yes!
3. Let me say that one more time – YES!

The next question is often “What brand of hybrid should I get?” The answers to this question are numerous, and they all start with the phrase “I don't know - that depends on . . .” The brand and model of hybrid you get depends on several factors, including the type of phone system you have, the need to handle multiple callers, the need to treat callers differently on air than off air, whether you want callers to hear each other, and so on.

Having said that, it's also true that, depending on the console and how it deals with callers, some hybrid features are more desirable than others to search for. We will touch briefly on some of these issues at the appropriate point in the discussion.

1.5 A Quick Quiz

OK, please answer this question: I want to interface my Audioarts Engineering console with my station's phone system. Do I need to use a hybrid?

If you are unsure of the answer, please reread the above sections.

1.6 What Can I Expect From The Console?

We covered a lot of ground very quickly to get to this point in the discussion. We've now arrived at the good stuff.

The console is, in many ways, the heart of your broadcast facility. Sure, if we made transmitters I'd say the transmitter was the heart, but, really now, the console *is* the heart of the facility.

If our facility is engaged in broadcast that includes telephone audio as one of its sources, then the console and the hybrid have to play well together. To verify that this will be the case, you need to understand how the two work separately and together. We have already covered the workings of the hybrid, although not in any great depth. We defer explanation of the details to the folks who make the boxes.

Now we will dig into the console in enough detail to make you dangerous.

1.6.1 Consoles Without Dedicated Caller Hardware

First let's consider the minimalist approach. In this case, the console provides nothing special in regard to handling phone calls, but you can still do the job to a limited degree. This is the approach taken with the Audioarts Engineering Air 1, our lowest priced console. This is also the way it was done before dedicated phone modules were available.

In this approach, caller audio from the hybrid is brought in on a normal console input, and audio back to the caller comes from an output bus that other input modules can be assigned to. Since the caller inputs and outputs are mono signals, some thought needs to be given to the connections if stereo inputs or outputs from the console are used. This will be covered more thoroughly when we discuss the handling of multiple callers in section 4.

In order to have the caller as part of the air signal and also have the caller hear audio from the console, the console must have two output busses available at minimum. One bus will provide the normal air

feed and the other bus will provide the mix-minus audio back to the caller. For audio that you want to be on air and also available for the caller to hear, assign that source's channel to *both* busses. The key thing to remember is that you *must not* assign the caller input channel to the bus that provides the audio back to the caller. If you forget this you *will* experience feedback, and not in the *good* sense.

Multiple callers can be handled with this approach. If you need audio returned to one caller to include another caller's voice, you will need to have a separate bus available for each caller feed, in addition to the air bus. Although this is really a conferencing issue it bears mention here since it impacts the number of callers that can be handled, based on the available console outputs.

1.6.2 Consoles With Dedicated Caller Hardware

Now let's take a step up to a console that provides a special input to handle one single caller. This approach is represented by both the Audioarts Engineering Air 3 and Air 2+ analog consoles, and the Audioarts Engineering W-12 digital console as well.

In this approach, caller audio from the hybrid is brought in on a dedicated caller input, and a special output sends a mix-minus of one of the standard output busses back to the caller. This approach is generally much easier on the operator than the minimalist approach, since there is no need of being wary of which bus the caller is assigned to, at least in regard to feedback. The caller audio simply cannot be accidentally returned to the caller by any action the console operator can perform, as long as everything is connected properly and nothing is blatantly broken.

The dedicated caller mix-minus can generally be used in conjunction with any of the console's main output busses, and is usually determined by the bus or busses we have decided to assign the caller to. If, for example, we assign the caller to the PGM bus, then the mix-minus back to the caller will be whatever is on the PGM bus, but without the caller voice included. In most cases you can assign the caller to multiple busses in the console¹. You should be wary when doing this, since the caller will hear certain sources louder than others if some sources are only on one of the selected busses but other sources are on more than one bus.

The Audioarts Engineering R-55e also uses this approach, but an additional caller can be handled by adding a second dedicated phone module. There is no impact on mix-minus; however, internal conferencing is not supported when multiple phone modules are used in these consoles.

2. Handling A Single Caller

Now let's discuss handling a single caller on a console that has dedicated caller hardware.

2.1 Getting Caller Audio To The Console

Assuming the hybrid can handle only one caller, the hybrid will have one audio output connection that will feed the caller's voice to the console. The name given to this output may vary from manufacturer to manufacturer, or even from model to model by a given manufacturer. And the characteristics of the audio connection, as well as the connector type, can also vary. You will need to read the hybrid's manual to help you determine how best to make the connection.

You will also, of course, want to read the console manual. If you *don't* want to read the console manual, read it anyway! But, as far as Audioarts Engineering is concerned, you will always find that the caller input to the console is a professional quality balanced analog connection designed to receive

a +4dBu signal. So if your hybrid provides a balanced +4dBu analog output, you only need to connect the two with a good quality shielded pair cable. For the uninitiated, the audio connections will be labeled HIGH (or H, or +), LOW (or L, or -), and SHIELD (or S, or GND, or COMMON). Connecting is always done from HIGH to HIGH with one wire of the shielded pair, from LOW to LOW with the second wire of the shielded pair, and from SHIELD to SHIELD with the outer shield of the cable. The two wires of the pair are usually color coded in some fashion to help you avoid cross-connecting HIGH and LOW.

If your hybrid has an unbalanced audio output, then the connection will be a little different. There are two approaches to take. Ideally, you would use a balun (**balanced-to-un**balanced converter) designed to interface the +4dBu balanced professional audio world with the (typically) -10dBV unbalanced commercial audio world. But if that luxury is not available there is a second option. Using the same type of shielded pair cable that we use with balanced connections, connect the hybrid output hot side (typically the center pin of an RCA type connector) to the console HIGH input with one wire of the pair and connect the hybrid output ground side (typically the shell of the RCA connector) to the console LOW input with the other wire of the pair. Then connect the cable shield to the console SHIELD input, and leave the cable shield disconnected at the hybrid end.

2.2 Getting Audio Back To The Caller

In the other direction, the console caller feed audio output has to be fed back to the hybrid. On Audioarts Engineering consoles this will always be a professional quality +4dBu balanced analog connection. Once again, the connection at the hybrid end may vary. Also once again, connection is simple if the hybrid has the same +4dBu balanced connection, but if not you are once again faced with two choices. The first choice (need I say once again?) is to use a balun type device. If one is not available, you can still wire things up, but the method you use will depend on the console's output circuit. Rather than try to address the issue in this paper, please refer to your console manual's discussion of unbalanced connection wiring.

2.2.1 Mix Minus

Mix-minus is a topic that befuddles most of us when we're first exposed to the concept, so it begs more discussion than some of the other topics we encounter.

First, think of the term “mix” as it applies to audio. If I have one guy talking into a mic and that's the only thing I'm broadcasting, I don't have a mix. But if I add a CD player, even if the voice and the music don't occur at the same time, I *do* have a mix. I have “mixed” two signals together and now I have to be aware of how loud one is in relation to the other. That's really simple mixing in a nutshell: balancing the volume of two (or more) audio sources. Sure, there's more to it than that, but for the purpose of our discussion that serves to define the term adequately.

Now the “minus” part – this is where the best of us have stumbled from time to time. The caller should never be hearing his or her own voice coming back over the telephone. This is the very practical consequence of the basic fact that, by the time the caller's voice has reached across the phone lines and gotten into the mix output of the console, there has been a noticeable delay. And by the time that the signal you send back has gotten to the caller's ear, even more time has elapsed. As a result, the caller says something and brief moments later hears a voice repeating the words just spoken. Very disconcerting. And annoying.

For this reason you *always* want to be sending the caller a *mix* that is *minus* the caller's voice.

The mix-minus may be generated in the hybrid, or it may be generated in the console, or it may be done in both places. It's usually not good if it is generated in both places at once if mix-minusing is done by a *nulling* process. Briefly, if I have audio with a voice and music and I null that audio with audio that is only the voice, the nulling process adds the voice to the mix, but out of phase. If the phase and levels are right, the voice is canceled, or nulled, from the mix, creating a mix minus. But if I *assume* that the incoming audio is a mix of the voice and the music, and, acting on that assumption, add the voice to the mix out of phase, and further, if the incoming audio actually is a mix-minus already, so that the voice is *not* present, my attempt to cancel it by adding it out of phase will not cancel it after all, but what I have done instead is to take a perfectly good mix-minus and re-infect it, if you will, with the undesired voice component.

Go ahead and read that last paragraph again if you need to.

2.2.2 Generating The Mix Minus

We've explained the idea of what a mix-minus is in fair detail. What we want to discuss next is some of the approaches Audioarts Engineering has taken to the topic of creating a mix-minus that your hybrid can work with.

One mix-minus method was mentioned above in section 2.2.1. This is the nulling method. As inferred, this method takes advantage of the fact that when a signal is added to a copy of itself at exactly the same magnitude and exactly 180 degrees out of phase with the original, the two signals cancel, or *null*, each other out, and the result is that the signal essentially disappears. The problem with this method is wrapped up in that simple word "exactly." We can seldom insure that the copy is either *exactly* the same level or *exactly* 180 degrees out of phase with the original, especially over a range of frequencies, even the limited range of frequencies used in POTS. Variables such as uneven frequency response and unpredictable circuit impedances play havoc with the nulling process. Thus the nulling technique, although usable in many situations, is not the ideal way to handle mix-minus generation.

Audioarts Engineering consoles do *not* use nulling to generate the mix-minus.

What we use instead, in most of our analog consoles, is a process that might be called "downstream insertion." With this method, the caller voice is inserted into the bus signal path at some point after the point where we take the signal off the bus to feed it to the caller. The success of this technique is dependent on a circuit being unilateral, which is to say, in simple terms, that signal flows in one direction but not the other. In the real world there is no such thing as a completely unilateral circuit; this is a characteristic of the elusive "ideal" amplifier. But with modern circuit topologies and components one can achieve a signal path that is very highly unilateral. In practice, this method gives us excellent mix-minus characteristics over the audio range, and is used in the Audioarts Engineering Air 3, the Air 2+, and the R-55e.

The older R-5 console employed a different, but equally effective, approach. That console has a dedicated TEL bus that serves as the caller feed output. All inputs save the caller input can assign to this bus as well as to the PGM and AUD busses. However, although the caller input can still assign to both PGM and AUD, it cannot be assigned to TEL. There is simply no switch provided to make this assignment. For lack of a better name, let's call this technique "prohibited routing."

A similar approach to the R-5's prohibited routing is applied to the D-75 and W-12 consoles. In this case the mix-minuses are created in the digital realm, and the rules simply block, or prohibit, a caller

input from being included in its corresponding caller output mix.

2.2.3 What's In The Mix

Sometimes you may want to know where the caller feed is coming from, *i.e.*, what console bus, or busses, contribute to the feed to the caller. Audioarts Engineering has used a few different methods of selecting the source bus. With the Air 3, Air 2+, and R-55e consoles, the caller feed is derived from the same bus or busses that the caller audio is assigned to, while with the D-75 and W-12 consoles, the caller feed is derived from a single bus selected with the MXM FEED switch (D-75) or CALLER FEED switch (W-12).

Many of the Audioarts Engineering consoles have a feature known as Talkback, and more specifically, Talkback to Studio, that, in some consoles, is pertinent to telephone interfacing as well. In essence, the Talkback (TB) bus is a separate bus to which selected sources can be routed pre-fader and pre-on. In some of these consoles the TB bus is also available as a caller feed source, to be used to talk to the caller while the caller is not on air. The big variation is in what sources can feed the TB bus.

In the Air 3 and the Air 2+, mic 1 always feeds the TB bus, and no other sources can feed TB.

In the D-75 any combination of inputs can be assigned by a dip switch setting to the TB bus. This is true of the older D-16 as well, with the difference being that, in the unique D-16 console input sources can be assigned to TB even if they are not routed to a fader.

In the W-12 any combination of the first four channels can be assigned to the TB bus.

In the consoles listed, except for the Air 3 and the Air 2+, the TB bus feeds the caller when the caller channel is put into CUE. In the Air 3 and Air 2+ the TB bus feeds the caller when the phone TB switch is pressed and held.

Sometimes it is handy to be able to bring an additional source into the console for the caller to hear without using up a normal input channel. For example, we may want to provide an air monitor version of our broadcast as music-on-hold when our phone system does not have this provision. The D-75 phone module has an external input to provide this feature. The D-16 takes this idea a step further and allows you to route any console input to the caller, and provides the ability to have the caller feed source change automatically as the caller module is turned on or off.

2.3 Off Air

With a single caller, what are we likely to want to do when we are off air?² Certainly the host needs to be able to talk to the caller. This often (but not always) implies that the host is not talking on air at the same time. Possibly we want the caller to also hear a song that's playing, or a segment giving clues for a contest, or some such audio that is on the air. And we certainly want the host to be able to hear what the caller is saying.

A common feature in Audioarts Engineering consoles with dedicated caller handling is an off air intercom of sorts, selected by a button that has been variously labeled SETUP, COM, or CUE. Typically, when this button is pressed, the caller audio appears on the console cue speaker, allowing the host to hear the caller. At the same time, provision is made so that the host can talk to the caller and/or play an audio segment for the caller to hear. The mechanism varies from console to console. Sometimes a bus is available that can be assigned to on a pre-fader, pre-on basis from input modules, thus allowing the host mic to be available on that bus even if the input handling that mic is turned off

and the fader is all the way down. In this case the bus is usually routed to the caller by pressing a bus assign button or a dedicated "caller feed" button. In other consoles, an internal talkback bus having the host mic and, possibly, other sources, is routed to the caller. This was discussed in section 2.2.3 above. If the host is on air, talking to the caller may be as simple as giving the caller a feed from the PGM bus.

2.4 On Air

When the caller is on air, things are easier. If the caller is feeding PGM and the host is listening to PGM, the host hears the caller. And if the caller feed is set up to be a mix-minus of PGM, then the caller hears the host. Mission accomplished.

2.5 Recording

Sometimes we want to record a caller segment for later air play, or for archival purposes. One approach is to use an otherwise unused bus, such as AUX (assuming such a bus exists in the console). We can assign the sources we want to be recorded, such as the host, some music, and, of course, the caller, to this bus. Then we simply feed the bus output to the recorder.

One problem with this approach is that we may not get an ideal mix of caller voice against the rest of the recorded material. The D-75 console has some additional outputs that can help.

2.5.1 Other Phone Specific Outputs

As just mentioned, the Audioarts Engineering D-75 console phone module provides three additional and useful outputs.

The *Composite* output combines the caller feed audio with the caller audio.

The *Composite Minus Callers* output includes all the audio that is feeding all the caller outputs, except that none of the caller audios appear in this output.

The *Caller Sum* output includes the audio from all callers, but does not contain any other of the audio sources that comprise the caller feed.

How are these outputs used in recording? The *Composite* output can be handy if you want to make a mono recording of caller segments without having to dedicate a main console bus to the task. The *Composite Minus Callers* output is most often used to provide the audio for one side of a stereo recording, with the *Caller Sum* output providing the other side of the stereo recording. This allows balancing caller audio against the other sources when mixing down to mono at a later time.

A secondary usage of the *Composite Minus Callers* output is to serve as the feed back to the hybrid when you want to do your conferencing in the hybrid and not in the console, or when you *must* do the conferencing in the hybrid, in cases where the hybrid does not allow you to disable caller conferencing, as will be discussed in section 3.2.2 below.

3. Handling Two Callers

As far as wiring the dual hybrid audio outputs to the console, it's the same as wiring the single hybrid, just done twice. All of the same issues discussed in sections 2.1 and 2.2 above apply.

To wire the audio output from the console back to the hybrid, there are a couple of issues to consider beyond the balanced versus unbalanced question.

Some hybrids will have a pair of inputs, one for each caller. In that case, it's the same as wiring the single hybrid, but doubled. On the other hand, some hybrids have only one input back to the callers, and the distribution of caller feed to the callers is handled internal to the hybrid. In that case you need to do some thinking about the best way to provide that feed.

If the console provides dedicated support for two callers, and also has a *Composite Minus Callers* output (like the D-75), then use that output to feed back to the hybrid. If the console has two caller outputs but does not have the *Composite Minus Callers* output, you'll probably have to use a normal bus output to feed audio back to the hybrid, and do the appropriate bus assignments in the console to make the right audio happen.

It may also be that you have a hybrid that only handles one caller but you need to handle two. In this case you'll either need to get a second single caller hybrid or step up to one with higher caller capability. A third option is discussed in section 3.2 below.

3.1 Conferencing

Much easier to understand than the elusive mix-minus is the idea of conferencing. Conferencing is not an issue when dealing with a single caller. With multiple callers, conferencing is the name given to the procedure that allows the callers to hear one another.

There are three ways in which you might be dealing with multiple callers. You might be using a console that has no dedicated phone inputs, in which case you'll be bringing each caller in on a normal input module. Or you might have one or more dedicated phone inputs but need to bring in an additional caller or so on a normal input (see section 3.2). Or you may have a console that has enough dedicated inputs for the number of callers you deal with. Regardless of which case applies, you need to make a decision. Will you have the callers hear each other, or not? If the answer is yes, then you need caller conferencing, either in the hybrid or in the console.

The Audioarts Engineering D-75 provides caller conferencing. This conferencing feature can not be defeated. However, conferencing is done post-fader, so that how loudly caller two hears caller one depends on where the caller one fader is positioned. If you are talking to caller two off line and don't want caller two to hear caller one, make sure the caller one fader is brought all the way down, or that you have a way to externally switch the caller feed off for each caller independently.

3.1.1 Too Much Conferencing

Like mix-minusing, conferencing may be done in either the hybrid or the console, and, once again, it is *not* a good idea to do it in both places. Here the problem is less one of delay and more one of level. If everything is in phase with minimum phase shift and conferencing is done at similar levels in both the hybrid and the console, the net result will be that caller two will appear 6dB louder to caller one than would be the case if conferencing is done only in one place, and the same is true of the level of caller one that caller two hears. With one of the interconnecting cables wired out of phase conferencing could disappear completely for one caller. And any added phase differences between the two conferencing paths will result in some addition and some cancellation, resulting in what we professionals call “weird sound.”

One unwelcome problem that can show up is the situation where your console has conferencing and your hybrid has conferencing, and neither can be disabled.

As mentioned, one caller may hear another at a level much higher than if conferencing was only done in one place, or the level may be much lower. One caller's voice may possibly be canceled all together, or there can be addition at some frequencies and cancellation at others, resulting in a generally poor experience for the caller.

So what can we do? We need to eliminate conferencing at one location or the other.

At the console end, if this is an Audioarts Engineering console with multiple caller capability, our only choice to eliminate conferencing is to use outputs other than the normal dedicated caller outputs to feed the callers. If the phone module has the *Composite Minus Callers* output, using that will take care of the problem. If the hybrid has separate inputs for sending audio back to the caller, split the *Composite Minus Callers* output to feed both these inputs. If the hybrid has a single input and internally splits this input to provide the two caller feeds, then simply connect it and go.

If the phone module does not have a Composite Minus Callers output, you'll need to feed both callers from separate bus outputs that do not include the other caller.

Methods of bypassing a non-defeatable conferencing feature in the hybrid are beyond the scope of this article.

3.1.2 Not Enough Conferencing

But what if my console doesn't provide conferencing, and neither does my hybrid, but I still need the callers to hear each other?

For an example of this, let's look at the R-55e, and, for the purpose of the example, let's say you have two SPN-55e Superphone modules. The R-55e console allows the use of two phone modules but does not provide conferencing between the callers. Further, let's say you are using two single caller hybrids, so that we know there is no conferencing taking place in the hybrid. Setting up without conferencing in this case is easy. Just wire hybrid 1 to the first SPN-55e, and wire hybrid 2 to the second R-55e.

The connections so far look like this:

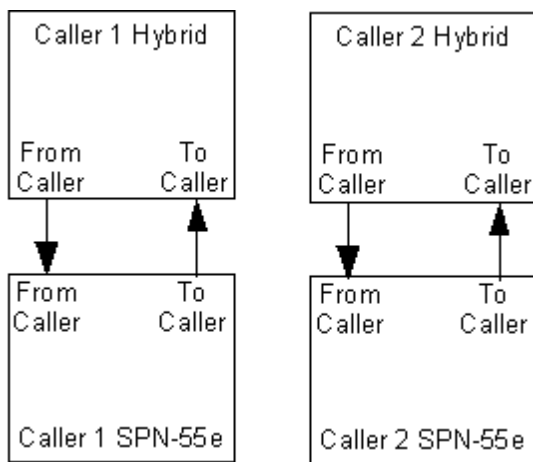

OK, now let's add the external conferencing. We need to use two summing amplifiers; each amplifier

needs two inputs. We use the first summer to add caller two audio to the feed to caller one, and the second summer to add caller one audio to the feed to caller two. What we now have looks like this:

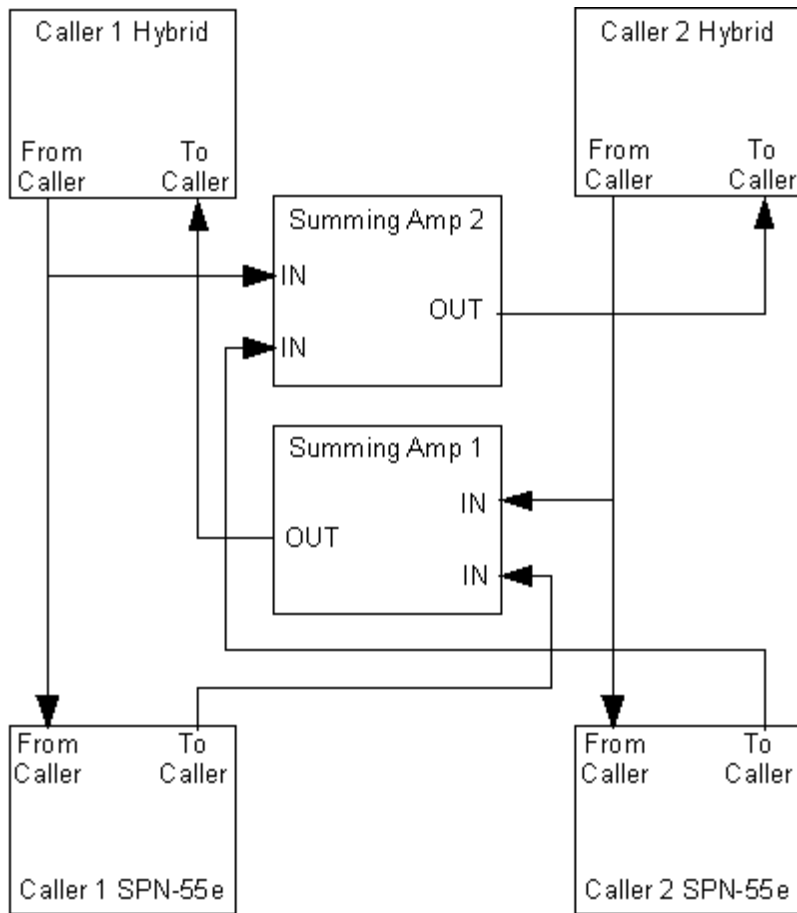

Various types of inexpensive summing amplifiers are available, and the choice is left up to you.

3.2 Two Callers, One Caller Channel

This section asks the musical question, “What do I do if my console only handles one caller, but I need to handle two with it?” We will frame our discussion around the idea of handling two callers with a console designed to handle one, but the same approach can be further extended, both in terms of adding more than one caller and in starting with a console that has provision for more than one caller to start.

Basically, the idea is to combine the console's dedicated caller capabilities with the minimalist approach outlined in section 1.6.1 by using a normal console input to handle the second caller.

As for handling more than two callers, you may have a hybrid that handles the required number of callers, or you may have to use multiple hybrids. In either case you'll need to apply the appropriate techniques, as already discussed, based on a thorough reading of the equipment manuals.

3.2.1 A Simple Example

Let's use the R-55e as an example, and limit our discussion to handling an on air caller segment.

Caller one is brought in on the dedicated SPN-55e Superphone Input Module. The caller audio from the hybrid that is handling caller one comes in on the SPN-55e caller input, and the SPN-55e caller output feeds back to the caller one hybrid.

Caller two is brought in on an SL-55e Stereo Line Input Module. The caller audio from the hybrid that is handling caller two is wired to bridge both the left and right inputs of the SL-55e, so that the mono caller source is placed in both the left and right sides of the stereo busses. The PRE output from the console's OM-55e Output Module feeds back to the caller two hybrid.

For this discussion, let's agree that each caller needs to hear the other caller, but neither caller should hear his or her own voice. Further, assume that both callers will be hearing some additional audio, possibly a DJ voice, or a music bed, or perhaps both. How can we set this up?

Begin by placing the common audio on the console's PGM bus. Assign the SPN-55e to PGM. At this point, caller one hears the common audio without the caller one voice, and the caller one voice is on the PGM bus to be part of the air signal. Assign the common audio to the PRE, and caller two now hears the common audio.

Now assign the caller two SL-55e to PGM. This places caller two audio on air, and, since caller one is hearing the PGM bus, caller one is now hearing caller two.

We've now met all the criteria except one: caller two is not yet hearing caller one's voice. The temptation is to assign the caller one SPN-55e to PRE to send caller one's voice to the bus that caller two is hearing. But we have the common audio on both PGM and PRE, and if we assign caller one to both busses caller one will hear the common material from PGM and PRE summed together, thus increasing the level of the common audio over that of the caller two voice, which does not have the same advantage, being on PGM but not on PRE. If we tried to fix this problem by assigning caller two to PRE, then caller two hears his or her own voice – not a good thing!

So how do we get around this?

Look back at the discussion in section 3.1.2. We obviously don't want to implement the complete cross-conferencing solution shown there, but what if we only added summer two? This solves the problem by adding caller one's voice to the caller two feed without doing any additional undesired routing.

You still have to watch out for one thing. The board operator must not assign the caller two input module to PRE, as this will result in feedback and echo problems that will affect not only caller two but the quality of the air signal as well.

3.2.2 Other Consoles, Other Methods

It's beyond the scope of this paper to provide details about every combination of desired callers verses console type, but hopefully we've shown you enough about how all this phone stuff works so that you can think through your situation in terms of the equipment you have to work with. Read the manuals to determine what the equipment you have is capable of. Know where you are and where you need to get to, and if you have to make a compromise, know what's essential and what's not.

4. Handling More Than Two Callers

If you are dealing with one caller, or at most two at a time, then your hybrid only needs to deal with one or two phone lines. However, if your needs are greater, you may need to get a hybrid than can handle more lines, or else use multiple hybrids. Just bear in mind that the more caller inputs and caller outputs your hybrid provides for connection to the console, the more complicated things get when it's time to wire everything up. Multiple caller interfaces can also complicate things when you are actually operating the console and handling those callers.

If we are handling more callers than the console has dedicated outputs for, we sometimes have to use a regular bus output. Since caller audio is a mono signal, we ideally use a mono output from the console for the caller feed. Dedicated caller outputs from Audioarts Engineering consoles are always mono. However, there may be times when we need to use a stereo bus as the caller feed. If this is the case, we need to make a mono mix of the stereo output. It is never a good idea to simply tie the left and right outputs together. Instead, we have to use external summing resistors. Start by connecting a resistor (see below regarding the value to use) from the left output HIGH to a common point, and another resistor from the right output HIGH to the same common point. This common point then becomes the HIGH feed to the hybrid. If you are also using the LOW side of the output, you do a similar trick on the LOW connections.

All the resistors in this summing network need to be of the same value. Recommended resistor values are in the range of 620 ohms to 2 K-ohms (2000 ohms). Using too low a value will cause an excessive load on the console output, resulting in distortion and, in cases of excessively low values, premature failure of the output amplifiers. On the other hand, the higher the value of the resistors used, the lower will be the level of the audio getting back to the caller. This method works well as long as the input impedance of the hybrid is in the bridging range (10 K-ohms or higher). It may, however, present a problem if the hybrid uses the old standard of 600 ohms. In this case you may need to use an active summing circuit instead of a simple resistive summer.

5. Logic

One feature that may be important to your situation is the capability of an action on the console to cause a change in operation of the hybrid.

The most useful feature such is the ability of the console to provide a closure to the hybrid, so that the hybrid can do something useful, such as pick up a caller or hang up the line. The Audioarts Engineering Air 3 and Air 2+ provide the most basic functionality with a single START closure that is generated when the phone channel is first turned on. The D-75 provides both a START and a STOP function, with the STOP being generated when the module is turned off. The R-55e has both of these functions, and additionally has provision for an incoming logic signal from the hybrid to turn the phone channel on and off. The W-12 is somewhat different, in that the phone channel may be configured to use one of six logic ports. If so configured, it has an array of logic functions, including on, off, start, and stop. The same is true of the older D-16, except that it has eight assignable logic ports instead of six.

6. Summary

Handling caller audio in a radio broadcast situation introduces challenges that are not present in the simple broadcast of a DJ playing some tunes. But those challenges can be overcome with the right

equipment and some basic understanding of how to use that equipment.

Hopefully we've given you some ideas of how to make that happen with your Audioarts Engineering console.

NOTES

1. The standard version of the R-60 phone module is limited in this respect – the firmware only allows the caller to be assigned to one bus at a time. There is available, however, custom firmware for the module that allows caller assignment to multiple busses simultaneously.
2. In this paper we use the terms "off air" and "on air" relative to the caller's voice. If the caller's voice is in the mix to the transmitter, we are "on air." If not, we are "off air."

APPENDIX

We have concentrated for the most part on the Audioarts Engineering models in current production at the time this paper was written. The following table shows a comparison of features between not only the current models, but older models as well. This should be helpful in determining the best way for you to use an older console to handle caller segments.

	Air 3	D-75	R-55e	W-12	D-16	D-70	R-5	R-60	R-90	RD-12	
other models	Air 2+		[c]							[f]	
# of callers handled	1	2	1 [d]	1	2	2	1	1	2	4 [g]	
conferencing	no	yes	no	no	yes	yes	no	no	yes	yes	
logic	start/stop	[a]	yes	yes	[e]	[e]	yes	no	yes	yes	
	on/off	no	no	yes			no	no	no	yes	no
	other	no	no	no			no	no	no	no	no
TB to caller	yes	yes	no	yes	yes	yes	no	yes	no	yes	
external inputs	0	1	0	no	multi	no	no	no	no	1 [h]	
additional outputs	no	[b]	no	no	no	[b]	no	no	no	[b]	

Notes: [a] – start only

[b] – caller sum, composite, and composite minus callers

[c] – the older R-55 has the same caller-related features as the R-55e

[d] – additional callers can be handled with additional phone modules

[e] – logic port may be assigned for caller use

[f] – the RD-20 has the same caller-related features as the RD-12

[g] – caller module handles two callers, two modules allowed

[h] – each caller module has one external input, available to those two callers

The following Audioarts Engineering consoles have no dedicated caller hardware: Air 1, A-50, MR-40, R-10, R-16, and R-17.